

SECTION 2 - PERIODIC MAINTENANCE/TUNE-UP

2

TABLE OF CONTENTS

Periodic Maintenance Chart.....	2-2
Lubrication Points.....	2-3
Battery.....	2-3
Fuses.....	2-4
Air Cleaner/Filter.....	2-4
Valve/Tappet Clearance (Feeler Gauge Procedure).....	2-6
Valve/Tappet Clearance (Valve Adjuster Procedure).....	2-7
Testing Engine Compression.....	2-7
Spark Plugs.....	2-8
Muffler/Spark Arrester.....	2-8
Gas/Vent Hoses.....	2-9
Adjusting Throttle Cable.....	2-9
Adjusting Engine RPM (Idle).....	2-9
Engine/Transmission Oil - Filter.....	2-9
Front Differential/Rear Drive Lubricant.....	2-10
Tires.....	2-11
Steering Components.....	2-12
Driveshaft/Coupling.....	2-12
Suspension/Shock Absorbers/Bushings.....	2-12
Nuts/Bolts/Cap Screws.....	2-12
Ignition Timing.....	2-12
Headlight/Taillight-Brakelight.....	2-12
Switches.....	2-13
Reverse Shift Lever.....	2-13
Speedometer/Indicator Lights.....	2-15
Frame/Welds/Racks.....	2-16
Electrical Connections.....	2-16
Hydraulic Brake Systems.....	2-16
Burnishing Brake Pads.....	2-18
Coolant.....	2-18
Checking/Replacing V-Belt.....	2-18

Periodic Maintenance Chart

A = Adjust
C = Clean
D = Drain

I = Inspect
L = Lubricate
R = Replace

Item	Initial Service After Break-In (First Mo or 100 Mi)	Every Day	Every Month or Every 100 Miles	Every 3 Months or Every 300 Miles	Every 6 Months or Every 500 Miles	Every Year or Every 1500 Miles	As Needed	
Battery	I		I				C	
Fuses				I			R	
Air Filter/One-Way Drain	I	I	C*				R	
Valve/Tappet Clearance	I					I	A	
Engine Compression						I		
Spark Plugs	I			I			R (4000 Mi or 18 Mo)	
Muffler/Spark Arrester					C		R	
Gas/Vent Hoses	I	I					R (2 Yrs)	
Gas Tank Valve						I	C	
Throttle Cable	I	I			C-L		A-R	
Carb Float Chambers				D*				
Engine RPM (Idle)	I				I		A	
Engine-Transmission Oil Level		I					A	
Engine-Transmission Oil/Filter	R			R*			R	
Front Differential/Rear Drive Lubricant	I						R (4 Yrs)	
Tires/Air Pressure	I			I			R	
Steering Components	I	I		I			R	
V-Belt	I	Inspect every 100 hours/1100 miles						R
Suspension (Ball joint boots, drive axle boots front and rear, tie rods, differential and rear drive bellows)	I			I*			R	
Nuts/Cap Screws/Screws	I			I	I		A	
Ignition Timing						I		
Headlight/Taillight-Brakelight	I	I					R	
Switches	I	I					R	
Reverse Shift Lever					I		A-L	
Choke Cable	I			I	C-L		R	
Recoil Starter		I					C-R	
Handlebar Grips		I					R	
Handlebars	I	I					R	
Gauges/Indicators	I	I					R	
Frame/Welds/Racks	I		I		I			
Electrical Connections					I		C	
Complete Brake System (Hydraulic & Auxiliary)	I	I		C			L-R	
Brake Pads	I			I*			R	
Brake Fluid	I			I			R (2 Yrs)	
Brake Hoses	I			I			R (4 Yrs)	
Coolant/Cooling System	I		I				R (2 Yrs)	

* Service/Inspect more frequently when operating in adverse conditions.

Lubrication Points

It is advisable to lubricate certain components periodically to ensure free movement. Apply light oil to the components using the following list as reference.

- A. Throttle Lever Pivot/Cable Ends
- B. Brake Lever Pivot
- C. Auxiliary Brake Pedal Pivot
- D. Choke Cable Upper End
- E. Differential Lock Cable Ends
- F. Idle RPM Screw (Carburetors)

Battery

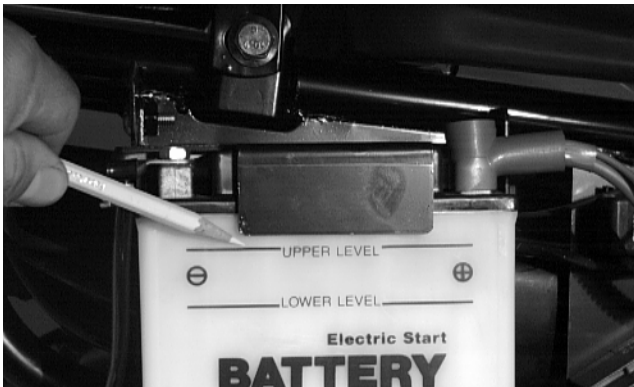

AF879D

The level of the battery fluid must be kept between the upper and lower level lines at all times. If the level drops below the lower level line, add only **distilled water** until it reaches upper level line.

⚠ WARNING

Battery acid is harmful if it contacts eyes, skin, or clothing. Care must be taken whenever handling a battery.

If the battery is discharged, remove the battery from the ATV and charge the battery at the standard charging rate of 1.4A x 10 hr.

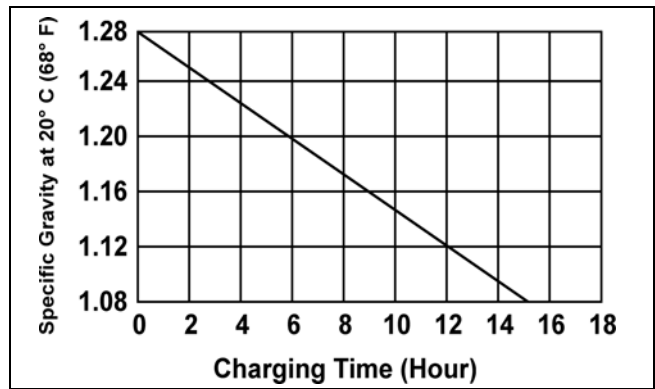

ChargeTim

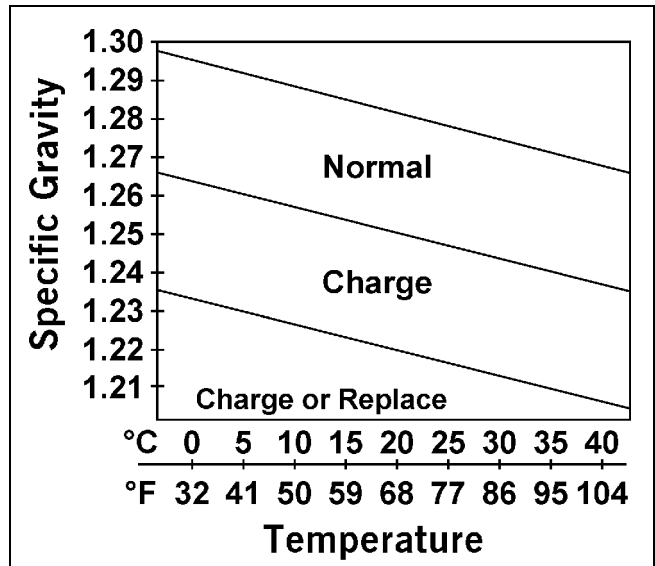

Charge

To remove and charge the battery, use the following procedure.

⚠ WARNING

Anytime service is performed on a battery, the following must be observed: keep sparks, open flame, cigarettes, or any other flame away. Always wear safety glasses. Protect skin and clothing when handling a battery. When servicing battery in enclosed space, keep the area well-ventilated. Make sure battery venting is not obstructed.

1. Remove the battery hold-down bracket.
2. Remove the negative battery cable; then remove the positive cable and the battery vent tube. Remove the battery from the ATV. Care should be taken not to damage the vent tube.

⚠ WARNING

Avoid spillage and contact with skin, eyes, and clothing.

⚠ CAUTION

Do not charge the battery while it is in the ATV with the battery terminals connected.

- Remove the vent plugs; then (if necessary) fill the battery with **distilled water** to the upper level indicated on the battery.
- Trickle charge the battery at 1.4 amps for 10 hours.

CAUTION

Never exceed the standard charging rate.

- After charging, check fluid level and fill with distilled water as necessary; then install vent plugs.

CAUTION

Before installing the battery, make sure the ignition switch is in the OFF position.

- Place the battery into position in the ATV and secure with the hold-down bracket.
- Attach the vent tube and check the vent tube to make sure it is not crimped or obstructed in any way and that it is properly routed through and secured to the frame.
- Connect cables to the proper terminals: positive cable to the positive terminal (+) and negative cable to the negative terminal (-). Connect the negative cable last.

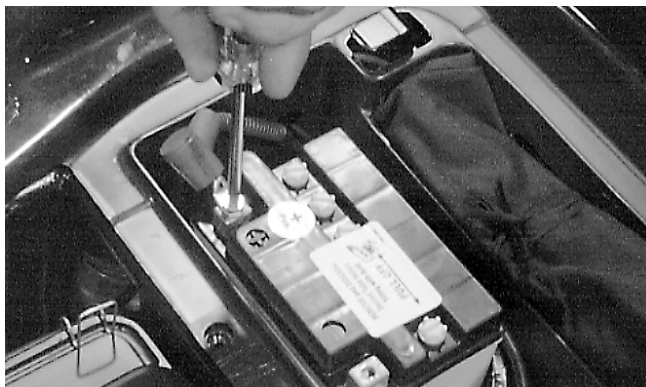

AF733D

CAUTION

Connecting cables in reverse (positive to negative and negative to positive) can cause serious damage to the electrical system.

FUSES

The fuses are incorporated into the Power Distribution Module which is located on the upper frame behind the right front fender.

If there is any type of electrical system failure, always check the fuses first.

NOTE: To remove the fuse, compress the locking tabs on either side of the fuse cover and lift off.

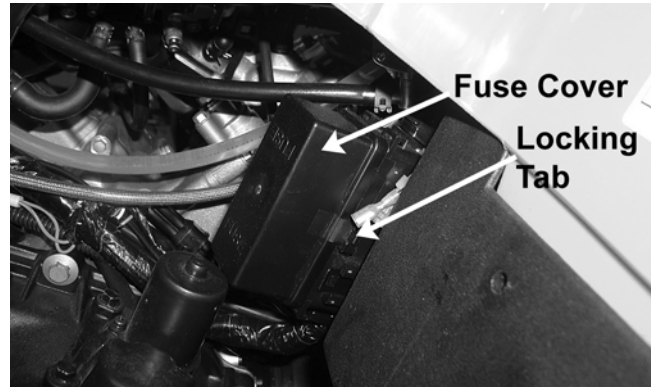

KX053A

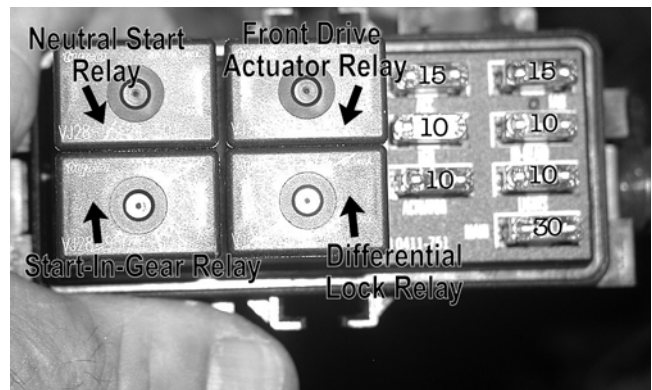

KX202A

CAUTION

Always replace a blown fuse with a fuse of the same type and rating.

Air Cleaner/Filter

The air filter inside the air filter housing must be kept clean to provide good engine power and gas mileage. If the ATV is used under normal conditions, service the filter at the intervals specified. If operated in dusty, wet, or muddy conditions, inspect and service the filter more frequently. Use the following procedure to remove the filter and inspect and/or clean it.

CLEANING AND INSPECTING FILTER

CAUTION

Failure to inspect the air filter frequently if the vehicle is used in dusty, wet, or muddy conditions can damage the engine.

- Remove the seat; then remove the screws securing the storage compartment cover housing and remove the housing and cover.



KX038

- Unsnap the four clips securing the storage compartment/filter housing cover; then remove and set aside.



KX031

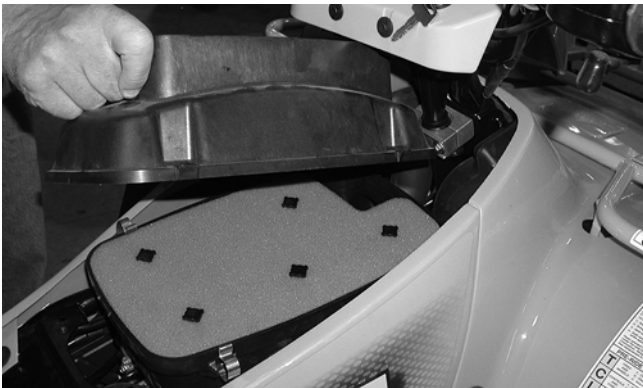

KX032

- Remove the air filter assembly and separate the foam element from the frame.



KX033

- Fill a wash pan larger than the filter with a non-flammable cleaning solvent; then dip the filter in the solvent and wash it.

■ **NOTE:** Foam Filter Cleaner (p/n 0436-194) and Foam Filter Oil (p/n 0436-195) are available from Arctic Cat.

- Dry the filter.
- Put the filter in a plastic bag; then pour in air filter oil and work the filter. Reattach the filter to the frame.

CAUTION

A torn air filter can cause damage to the ATV engine. Dirt and dust may get inside the engine if the element is torn. Carefully examine the element for tears before and after cleaning it. Replace the element with a new one if it is torn.

2

- Clean any dirt or debris from inside the air cleaner. Be sure no dirt enters the carburetor.
- Place the filter assembly in the air filter housing making sure it is properly positioned and properly seated with the filter frame down.
- Install the air filter housing cover and secure with the retaining clips; then install the storage compartment cover housing.
- Install the seat making sure the seat is properly secured.

CHECKING AND CLEANING DRAINS

- Inspect one-way drains beneath the main housing for debris and for proper sealing.

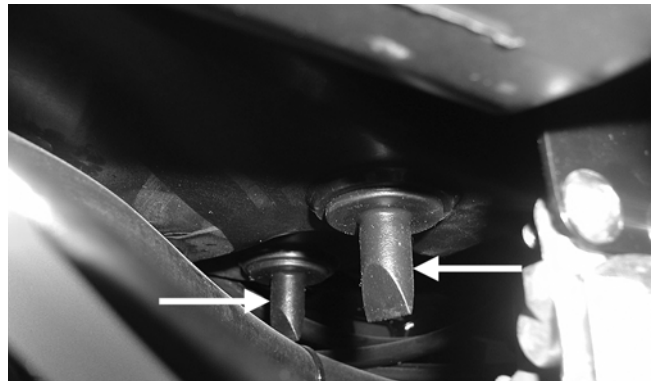

KX045A

- Replace any one-way drain that is cracked or shows any signs of hardening or deterioration.

CAUTION

The one-way drain to the right is the clean air section of the filter housing. Any leak of this one-way drain will allow dirt into the engine intake causing severe engine damage.

- Wipe any accumulation of oil or gas from the filter housing and one-way drains.

Valve/Tappet Clearance (Feeler Gauge Procedure)

To check and adjust valve/tappet clearance, use the following procedure.

■ **NOTE:** The seat, air filter housing, front fenders, front inner covers, and side panels must be removed for this procedure.

- Remove the cap screws securing the recoil starter; then remove the recoil starter assembly.
- Remove the timing inspection plug; then remove the four tappet covers (for more detailed information, see Section 3 - Servicing Top-Side Components).
- Rotate the crankshaft counterclockwise to the TDC position on the compression stroke indicated by the TR mark (A) on the flywheel. TR is top dead center front.

■ **NOTE:** At this point, the rocker arms and adjuster screws on the front cylinder must not have pressure on them.

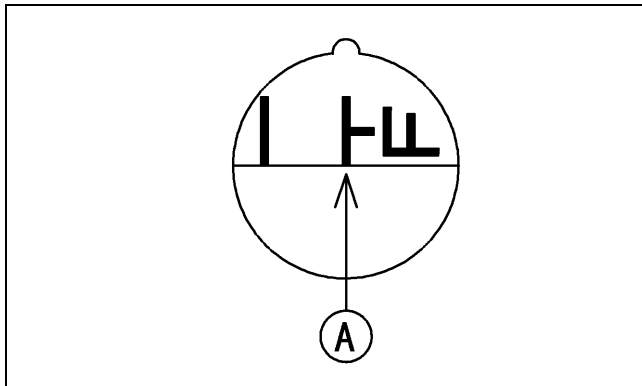

ATV2057B

- Using a feeler gauge, check each valve/tappet clearance. If clearance is not within specifications, loosen jam nut (B) and rotate the tappet adjuster screw (A) until the clearance is within specifications. Tighten each jam nut to 1.2 kg-m (104 in.-lb) after completing the adjustment.

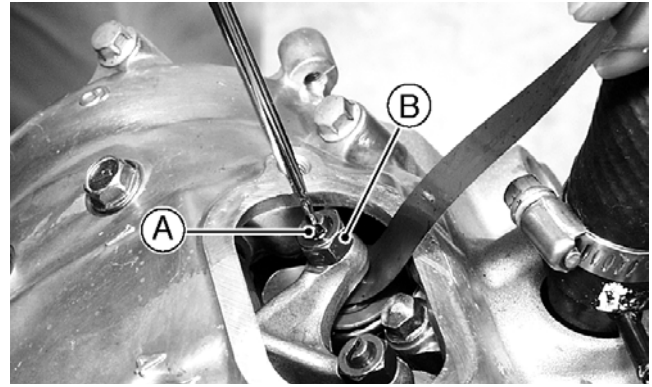

KX227

⚠ CAUTION

The feeler gauge must be positioned at the same angle as the valve and valve adjuster for an accurate measurement of clearance. Failure to measure the valve clearance accurately could cause valve component damage.

■ **NOTE:** Cold tappet clearance is 0.20-0.25 mm (0.0079-0.0098 in.) for exhaust valves and 0.10-0.15 mm (0.0039-0.0059 in.) for intake valves.

- Rotate the crankshaft counterclockwise until the TR mark (A) aligns in the timing hole. Repeat steps 3-4 for the rear cylinder.

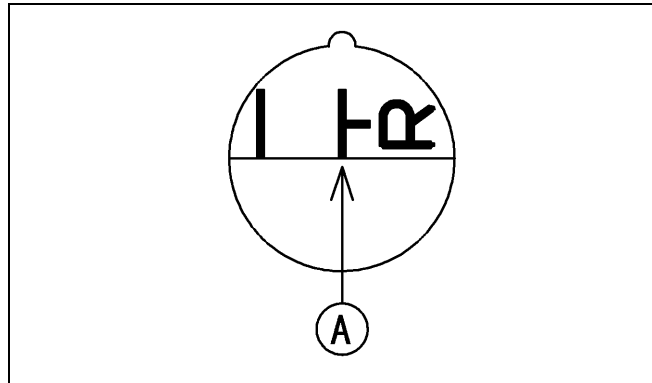

ATV2058B

- Install the timing inspection plug.
- Place the four tappet covers into position. Tighten the cap screws securely.
- Install the recoil starter assembly and tighten the cap screws securely.
- Install the air filter housing, front inner covers, front fenders, and side panels; then install the seat and make sure it locks securely.

Valve/Tappet Clearance (Valve Adjuster Procedure)

To check and adjust valve/tappet clearance, use the following procedure.

■ **NOTE: The seat, air filter housing, front fenders, front inner covers, and side panels must be removed for this procedure.**

1. Remove the cap screws securing the recoil starter; then remove the recoil starter assembly.
2. Remove the timing inspection plug; then remove the four tappet covers (for more detailed information, see Section 3 - Servicing Top-Side Components).
3. Rotate the crankshaft counterclockwise to the TDC position on the compression stroke indicated by the TF mark on the flywheel. TF is top dead center front.

■ **NOTE: At this point, the rocker arms and adjuster screws must not have pressure on them.**

■ **NOTE: Use Valve Gap Adjuster (p/n 0444-092) for this procedure.**

3. Place the valve adjuster onto the jam nut securing the tappet adjuster screw; then rotate the valve adjuster dial clockwise until the end is seated in the tappet adjuster screw.
4. While holding the valve adjuster dial in place, use the valve adjuster handle and loosen the jam nut; then rotate the tappet adjuster screw clockwise until friction is felt.
5. Align the valve adjuster handle with one of the marks on the valve adjuster dial.
6. While holding the valve adjuster handle in place, rotate the valve adjuster dial counterclockwise until proper valve/tappet clearance is attained.

■ **NOTE: Refer to the appropriate specifications in Feeler Gauge Procedure sub-section for the proper valve/tappet clearance.**

■ **NOTE: Rotating the valve adjuster dial counterclockwise will open the valve/tappet clearance by 0.05 mm (0.002 in.) per mark.**

7. While holding the adjuster dial at the proper clearance setting, tighten the jam nut securely with the valve adjuster handle; then tighten the jam nuts to 1.2 kg-m (104 in.-lb).

8. Rotate the crankshaft counterclockwise until the TR mark aligns in the timing hole; then repeat steps 3-7 for the rear cylinder.
9. Install the timing inspection plug; then install the four tappet covers and tighten securely.
10. Install the recoil starter assembly and tighten the cap screws securely.
11. Install the air filter housing, front inner covers, front fenders, and side panels; then install the seat and make sure it locks securely.

Testing Engine Compression

2

To test engine compression, use the following procedure.

1. Remove the high tension leads from the spark plugs.
2. Using compressed air, blow any debris from around the spark plugs.

WARNING

Always wear safety glasses when using compressed air.

3. Remove the spark plugs; then attach the high tension leads to the plugs and ground the plugs on the cylinder head well away from the spark plug holes.
4. Attach the Compression Gauge (p/n 0444-096) to the front or rear cylinder.

■ **NOTE: The engine must be warm and the battery must be fully charged for this test.**

5. While holding the throttle lever in the full-open position, crank the engine over with the electric starter until the gauge shows a peak reading (five to 10 compression strokes).

■ **NOTE: The compression should be within a range of 47-81 psi in the full-open throttle position.**

6. Repeat for the second cylinder.

7. If compression is abnormally low, inspect the following items.
 - A. Verify starter cranks engine over.
 - B. Gauge is functioning properly.
 - C. Throttle lever in the full-open position.
 - D. Valve/tappet clearance correct.
 - E. Valve bent or burned.
 - F. Valve seat burned.

■ **NOTE: To service valves, see Section 3.**

8. Pour 29.5 ml (1 fl oz) of oil into the spark plug hole, reattach the gauge, and retest compression.
9. If compression is now evident, service the piston rings (see Section 3).

Spark Plugs

A light brown insulator indicates that a plug is correct. A white or dark insulator indicates that the engine may need to be serviced or the carburetor may need to be adjusted. To maintain a hot, strong spark, keep the plugs free of carbon.

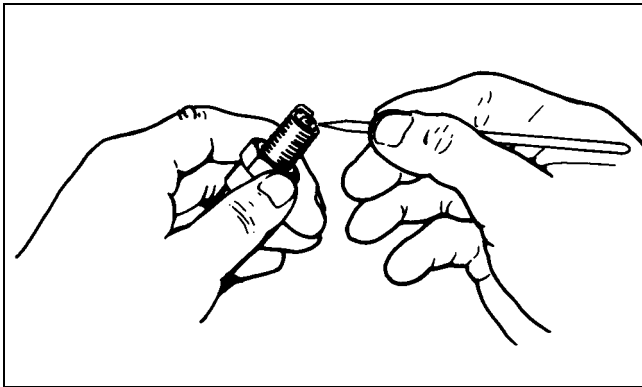

ATV-0051

⚠ CAUTION

Before removing the spark plugs, be sure to clean the area around the spark plugs. Dirt could enter engine when removing or installing the spark plugs.

Adjust the gap to 0.7 - 0.8 mm (0.028 - 0.032 in.) for proper ignition. Use a feeler gauge to check the gap.

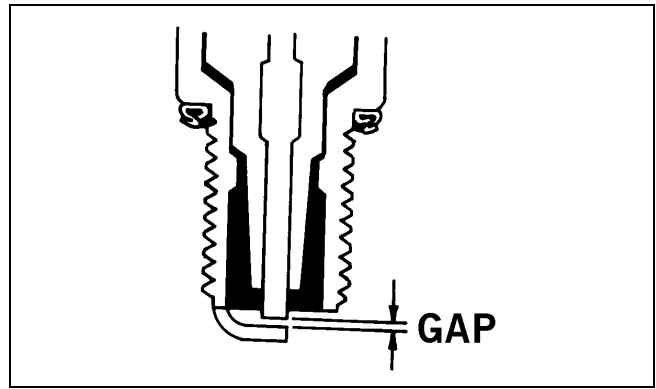

ATV0052B

When installing the spark plug, be sure to tighten it to 1.3 kg-m (9.5 ft-lb). A new spark plug should be tightened 1/2 turn once the washer contacts the cylinder head. A used spark plug should be tightened 1/8 - 1/4 turn once the washer contacts the cylinder head.

Muffler/Spark Arrester

The muffler has a spark arrester which must be periodically cleaned. At the intervals shown in the Periodic Maintenance Chart, clean the spark arrester using the following procedure.

⚠ WARNING

Wait until the muffler cools to avoid burns.

1. Shift the transmission into neutral and set the brake lever lock.
2. Elevate the front of the ATV on a safety stand until the muffler is horizontal.
3. Remove the plug from the bottom of the muffler.



KX051A

4. Start the engine and increase RPM to "blow out" the accumulated carbon particles.
5. Stop the engine. Wait until the muffler cools; then install the plug and tighten securely.

Gas/Vent Hoses

Replace the gas hose every two years. Damage from aging may not always be visible. Do not bend or obstruct the routing of the carburetor vent hose. Make certain that the vent hose is securely connected to the carburetor and the opposite end is always open.

Adjusting Throttle Cable

To adjust the throttle cable free-play, follow this procedure.

1. Slide the rubber boot away; then loosen the jam nut from the throttle cable adjuster.



AL611D

2. Slide the rubber boot away and turn the adjuster until the throttle cable has proper free-play of 3-6 mm (1/8 - 1/4 in.) at the lever.

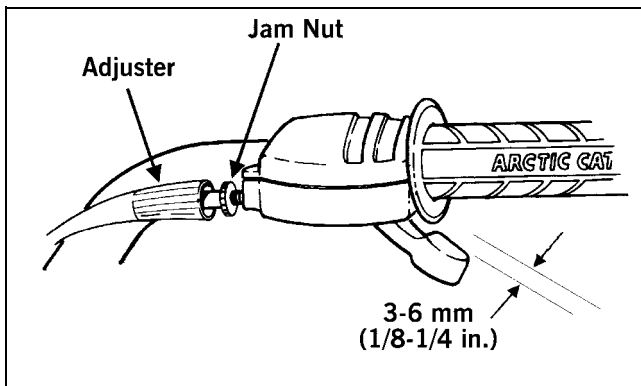

ATV-0047

3. Tighten the jam nut against the throttle cable adjuster securely; then slide the rubber boot over the adjuster.

Adjusting Engine RPM (Idle)

To properly adjust the idle RPM, a tachometer is necessary. To adjust idle RPM, use the following procedure.

1. With the transmission in neutral, start the engine and warm it up to normal operating temperature.
2. Turn the idle adjustment screw clockwise one turn past the recommended RPM setting; then turn it counterclockwise to 1050-1150 RPM.

2



KX029A

WARNING

Adjust the idle to the correct RPM. Make sure the engine is at normal operating temperature before adjusting the idle RPM.

Engine/Transmission Oil - Filter

OIL - FILTER

Change the engine oil and oil filter at the scheduled intervals. The engine should always be warm when the oil is changed so the oil will drain easily and completely.

1. Park the ATV on level ground.
2. Loosen the oil level stick/filler plug.

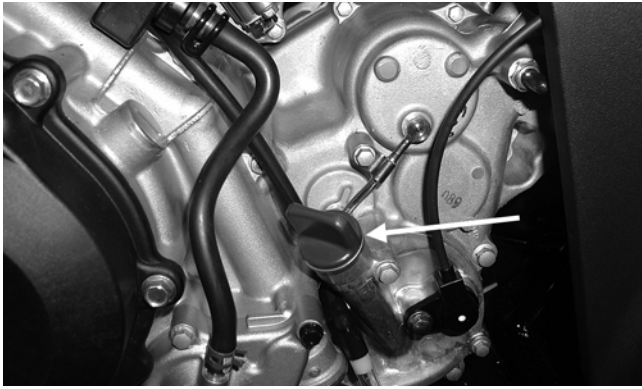

KX019A

3. Remove the drain plug from the bottom of the engine and drain the oil into a drain pan.



KX036A

4. Using the Oil Filter Wrench (p/n 0444-042) and appropriate handle, remove the old oil filter.

■ **NOTE:** Clean up any excess oil after removing the filter.

5. Apply oil to a new filter gasket and check to make sure it is positioned correctly; then install the new oil filter. Tighten securely.

■ **NOTE:** Install a new filter gasket each time the filter is replaced.

6. Install the engine drain plug and tighten to 2.0 kg-m (14.5 ft-lb). Pour 2.05 L (2.17 U.S. qt) of the recommended oil in the filler hole. Install the oil level stick/filler plug.

⚠ CAUTION

Any oil used in place of the recommended oil could cause serious engine damage. Do not use oils which contain graphite or molybdenum additives. These oils can adversely affect clutch operation. Also, not recommended are racing, vegetable, non-detergent, and castor-based oils.

7. Start the engine (while the ATV is outside on level ground) and allow it to idle for a few minutes.
8. Turn the engine off and wait approximately one minute.
9. Unscrew the oil level stick and wipe it with a clean cloth.
10. Install the oil level stick and thread into the engine case.

■ **NOTE:** The oil level stick should be threaded into the case for checking the oil level.

11. Remove the oil level stick; the engine oil level should be above the illustrated “L” mark but not higher than the illustrated “F” mark.

⚠ CAUTION

Do not over-fill the engine with oil. Always make sure that the oil level is above the “L” mark but not higher than the “F” mark.

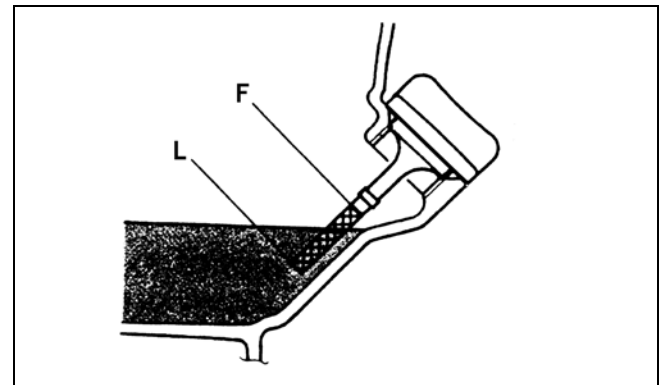

ATV0100A

12. Inspect the area around the drain plug and oil filter for leaks.

Front Differential/Rear Drive Lubricant

Check and change the lubricant according to the Periodic Maintenance Chart. When changing the lubricant, use approved SAE 80W-90 hypoid gear lube. To check lubricant, use the following procedure.

1. Remove each filler plug; the lubricant level should be 1 in. below the threads of the plug. If low, add SAE approved 80W-90 hypoid gear lube as necessary.

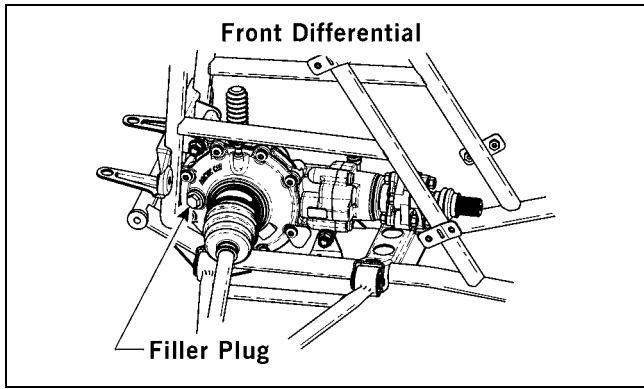

0736-568

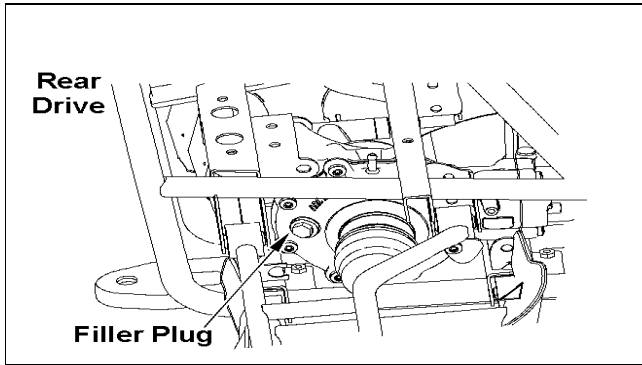

737-686A

To change the lubricant, use the following procedure.

1. Place the ATV on level ground.
2. Remove each oil filler plug.
3. Drain the oil into a drain pan by removing in turn the drain plug from each.

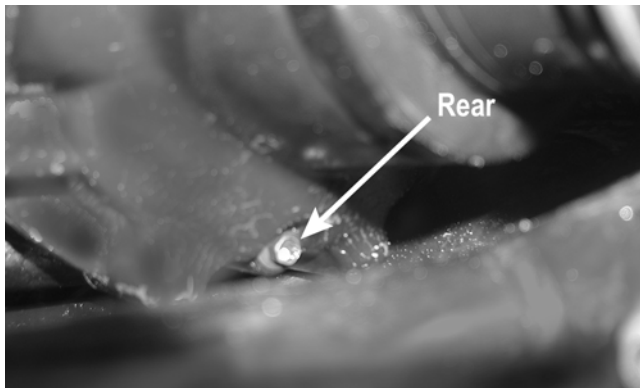

KX396A

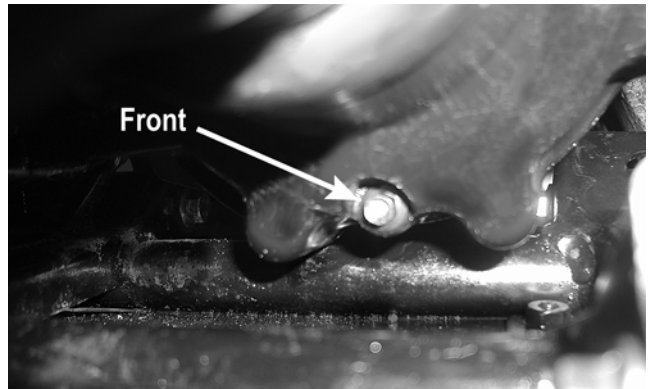

KX395A

4. After all the oil has been drained, install the drain plugs and tighten to 0.5 kg-m (3.5 ft-lb).
5. Pour the appropriate amount of recommended oil into each filler hole.
6. Install the filler plugs. Tighten to 2.2 kg-m (16 ft-lb).

■ **NOTE:** If the differential/rear drive oil is contaminated with water, inspect the drain plug, filler plug, and/or bladder.

⚠ CAUTION

Water entering the outer end of the axle will not be able to enter the rear drive unless the seals are damaged.

2

Tires

TIRE SIZES

The ATV is equipped with low-pressure tubeless tires of the size and type listed. Do not under any circumstances substitute tires of a different type or size.

⚠ WARNING

Always use the size and type of tires specified. Always maintain proper tire inflation pressure.

TIRE INFLATION PRESSURE

Front and rear tire inflation pressure should be 0.35 kg-cm² (5.0 psi).

A low-pressure gauge is provided in the tool kit to measure the air pressure in the tires. Check the air pressure in all tires before each use of the ATV.

Steering Components

The following steering components should be inspected periodically to ensure safe and proper operation.

- A. Handlebar grips not worn, broken, or loose.
- B. Handlebar not bent, cracked, and has equal and complete full-left and full-right capability.
- C. Steering post bearing assembly/bearing housing not broken, worn, or binding.
- D. Ball joints not worn, cracked, or damaged.
- E. Tie rods not bent or cracked.
- F. Knuckles not worn, cracked, or damaged.
- G. Cotter pins not damaged or missing.

Driveshaft/Coupling

The following drive system components should be inspected periodically to ensure proper operation.

- A. Spline lateral movement (slop).
- B. Coupling cracked, damaged, or worn.

Suspension/Shock Absorbers/Bushings

The following suspension system components should be inspected periodically to ensure proper operation.

- A. Shock absorber rods bent, pitted, or damaged.
- B. Rubber damper cracked, broken, or missing.
- C. Shock absorber body damaged, punctured, or leaking.
- D. Shock absorber eyelets broken, bent, or cracked.
- E. Shock absorber eyelet bushings worn, deteriorated, cracked, or missing.
- F. Shock absorber spring broken or sagging.

Nuts/Bolts/Cap Screws

Tighten all nuts, bolts, and cap screws. Make sure rivets holding components together are tight. Replace all loose rivets. Care must be taken that all calibrated nuts, bolts, and cap screws are tightened to specifications. For proper torque values, see Section 10.

Ignition Timing

The ignition timing cannot be adjusted; however, verifying ignition timing can aid in troubleshooting other components. To verify ignition timing, see Section 5.

Headlight/Taillight-Brakelight

Each time the ATV is used, lights should be checked for proper function. Rotate the ignition switch to the lights position; the headlights and taillight should illuminate. Test the brakelight by compressing the brake lever. The brakelight should illuminate.

HEADLIGHT

■ **NOTE:** The bulb portion of the headlight is fragile. **HANDLE WITH CARE.** When replacing the headlight bulb, do not touch the glass portion of the bulb. If the glass is touched, it must be cleaned with a dry cloth before installing. Skin oil residue on the bulb will shorten the life of the bulb.

WARNING

Do not attempt to remove the bulb when it is hot. Severe burns may result.

To replace the headlight bulb, use the following procedure.

1. Remove the wiring harness connector from the back of the headlight bulb assembly.
2. Grasp the bulb assembly and turn it counterclockwise to remove the bulb assembly from the housing.
3. Install the new bulb assembly into the housing and rotate it completely clockwise.
4. Install the wiring harness connector.

TAILLIGHT-BRAKELIGHT

To replace the taillight-brakelight bulb, use the following procedure.

1. Remove the two screws and remove the lens cover.
2. Push the bulb in and turn it counterclockwise.
3. Install the new bulb by turning it clockwise while pushing in.
4. Install the lens cover.

CAUTION

Tighten the lens cover screws only until they are snug.

CHECKING/ADJUSTING HEADLIGHT AIM

The headlights can be adjusted vertically and horizontally. The geometric center of the HIGH beam light zone is to be used for vertical and horizontal aiming.

1. Position the ATV on a level floor so the headlights are approximately 6.1 m (20 ft) from an aiming surface (wall or similar aiming surface).

■ **NOTE:** There should be an average operating load on the ATV when adjusting the headlight aim.

2. Measure the distance from the floor to the mid-point of each headlight.
3. Using the measurements obtained in step 2, make horizontal marks on the aiming surface.
4. Make vertical marks which intersect the horizontal marks on the aiming surface directly in front of the headlights.
5. Switch on the lights. Make sure the HIGH beam is on. **DO NOT USE LOW BEAM.**
6. Observe each headlight beam aim. Proper aim is when the most intense beam is centered on the vertical mark 5 cm (2 in.) below the horizontal mark on the aiming surface.

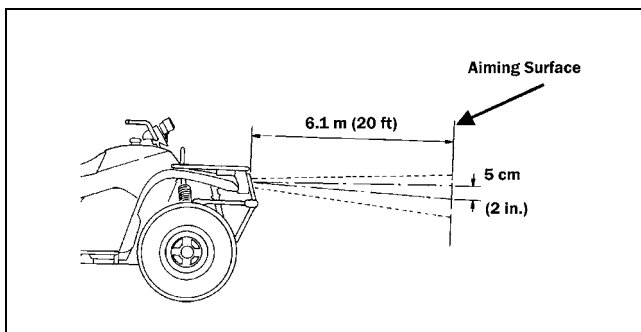

ATV-0070C

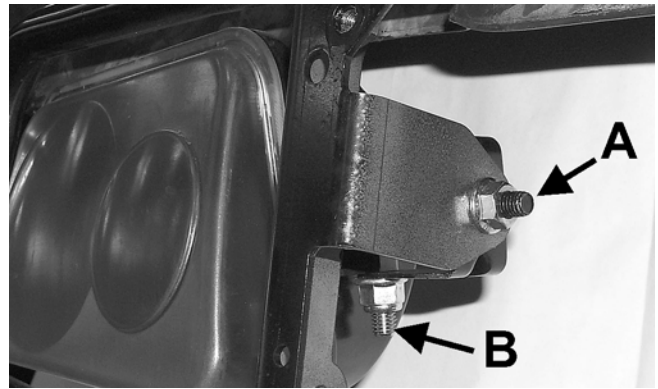

AF926A

7. Adjust each headlight until correct aim is obtained.

A. Horizontal — Loosen nut (A) and adjust for proper aiming. Tighten the nut securely.

B. Vertical— Loosen nut (B) and adjust for proper aiming. Tighten the nut securely.

2

Switches

Each time the ATV is used, switches should be checked for proper operation. Use the following list for reference.

- A. Ignition switch — engine will start.
- B. Emergency stop switch — engine will stop.
- C. Reverse switch — reverse indicator light illuminates.
- D. Hi/Lo switch — headlight beam bright and dim.
- E. Brake switches — rear brakelight illuminates.

Reverse Shift Lever

CHECKING ADJUSTMENT

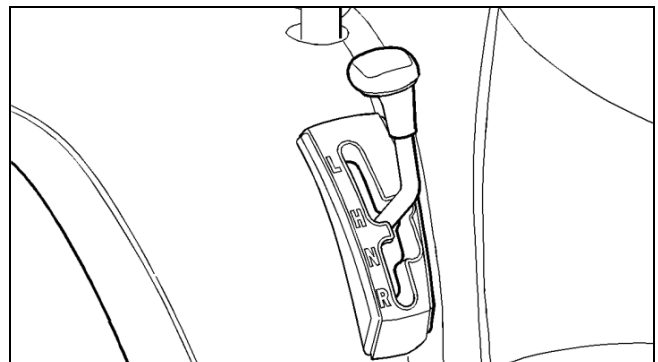

0736-565

Stop the ATV completely and shift the transmission into the R position. The reverse gear indicator light should be illuminated.

If the reverse lever light does not illuminate when shifted to the reverse position, the switch may be faulty, the fuse may be blown, the bulb may be faulty, a connection may be loose or corroded, or the lever may need adjusting. To adjust, proceed to Adjusting Shift Lever.

⚠ WARNING

Never shift the ATV into reverse gear when the ATV is moving as it could cause the ATV to stop suddenly throwing the operator from the ATV.

ADJUSTING SHIFT LEVER

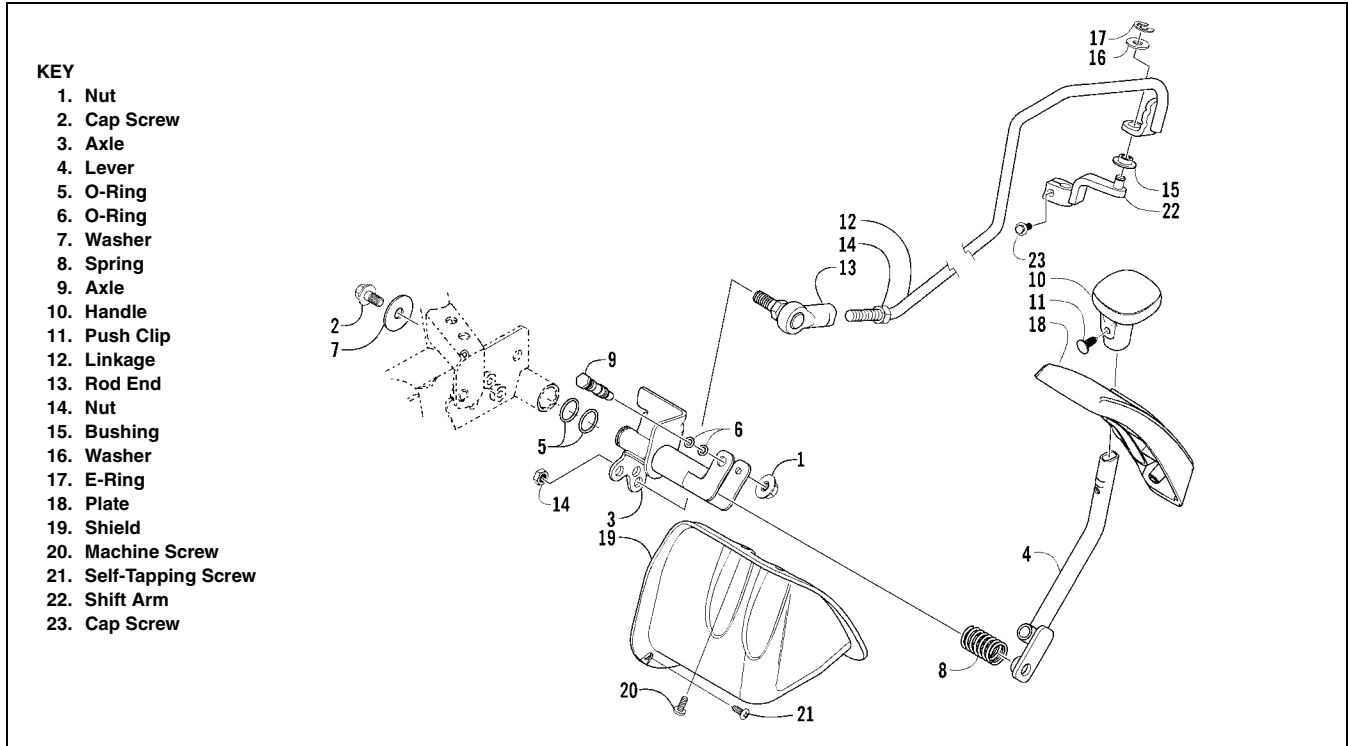

0739-083

1. Place the shift lever in the R position.
2. Remove the seat; then remove the storage compartment cover housing.
3. Remove the left upper body side panel.
4. Loosen shift rod end jam nut (A).

5. Using two open-end wrenches, remove lock nut (B) securing the shift rod to the upper shift axle. Discard the lock nut.

NOTE: Never reuse a lock nut. Once a lock nut has been removed, it must be replaced with a new lock nut.

6. Push the shifter arm to the most forward position (reverse).

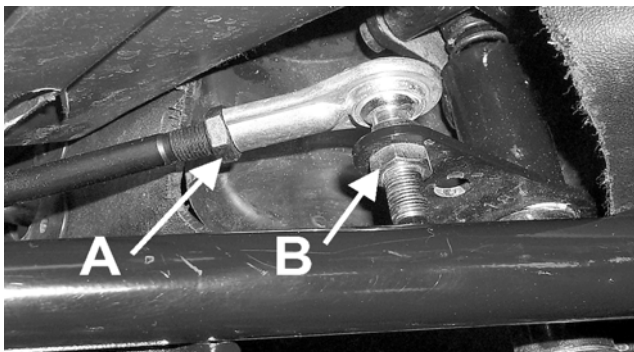

AF941A

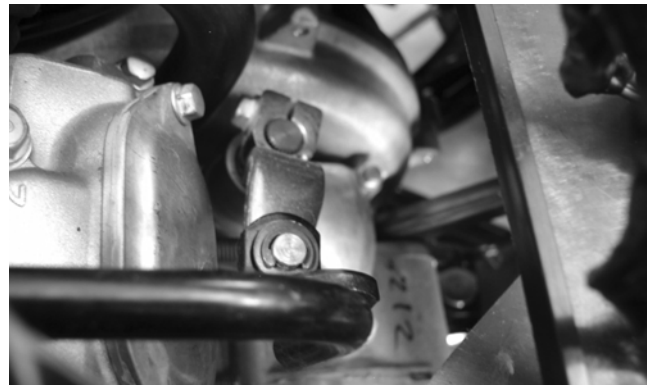

KX057

7. Rotate the shift rod end as necessary to align its threaded shaft with the hole in the shifter arm. Secure with a new lock nut (B). Tighten securely.
8. Tighten jam nut (A) to secure the adjustment.
9. Install the storage compartment cover housing; then install the seat making sure it locks securely.

Speedometer/Indicator Lights

Each time the ATV is used, the lights should be checked for proper function. Use the following for reference.

■ **NOTE:** The indicator lights will illuminate for approximately one second when the ignition switch is rotated to the ON position.

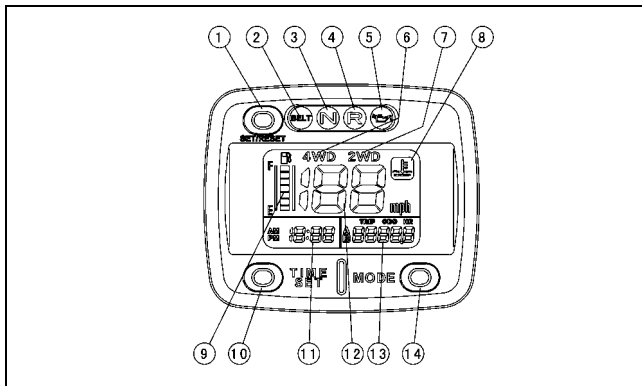

ATV2056

1. **Set/Reset Button** — Used (in conjunction with the Time Set button) to advance the hour and minute display for setting the clock and to reset the trip meter display to zero.
2. **Belt Check Indicator** — The Belt light will flash at 0.35-second intervals when excessive belt wear or belt damage is detected. Also, light will illuminate every 100 hours of operation to indicate service requirements.
3. **Neutral Indicator** — The Neutral light will illuminate when the transmission is in neutral and the ignition switch is on. The light will go out when shifted into any gear other than neutral.
4. **Reverse Indicator** — The Reverse light will illuminate when the transmission is shifted into reverse gear. The light will go off when shifted out of reverse.
5. **Oil Pressure Indicator** — An oil pressure warning symbol LED (light emitting diode) will flash when low oil pressure is detected.

6. **4WD Indicator** — Displays 4WD when the front drive selector switch is moved to the 4WD position. Display will go off when 2WD is selected.
7. **2WD Indicator** — Displays 2WD when the front drive selector switch is moved to the 2WD position. Display will go off when 4WD is selected.
8. **Coolant Temperature Indicator** — A red light will illuminate if the engine overheats. The light should be off during normal operation.

⚠ CAUTION

Continued operation of the ATV with high engine temperature may result in engine damage or premature wear.

■ **NOTE:** High engine RPM, low vehicle speed, or heavy load can raise engine temperature. Decreasing engine RPM, reducing load, and selecting an appropriate transmission gear can lower the temperature.

■ **NOTE:** Debris in front of the engine (or packed between the cooling fins of the radiator) can reduce cooling capability. Using a hose, pressure-wash the radiator and the engine to remove any debris preventing air flow.

9. **Fuel Level Indicator** — Shows amount of gasoline in the gas tank. When bottom portion flashes, 3.5 L (0.92 U.S. gal.) of gasoline remains in the tank.
10. **Time Set Button** — Press the button to set clock hours and minutes.

A. Press the button and the minute display will blink; then adjust the hour display by pressing the Set/Reset Button. Press the Time Set Button to set hour display.

■ **NOTE:** If the Set/Reset Button is pressed in and held, the hour display will advance continuously.

B. After the hour display is set, the minute display will blink. Press the Set/Reset Button to set minute display.

11. **Clock** — Clock indicates 12-hour mode.
12. **Speedometer** — Shows approximate ATV speed in km/h or mph.
13. **Odometer/Trip Meters (A & B)/Hour Meter** — Odometer registers the total distance the ATV has traveled. Trip meters can register two different types of distances (for instance, A could register trip distance and B could register distance between stops). Trip meters can be reset. Hour meter registers total ignition switch ON time.

14. **Mode Button** — Used (in conjunction with the Odometer/Trip Meters/Hour Meter) to shift the odometer/trip meters/hour meter display through the four modes: odometer, trip meter (A), trip meter (B), and hour meter.

Frame/Welds/Racks

The frame, welds, and racks should be checked periodically for damage, bends, cracks, deterioration, broken components, and missing components. If replacement or repair constitutes removal, see Section 8.

Electrical Connections

The electrical connections should be checked periodically for proper function. In case of an electrical failure, check fuses, connections (for tightness, corrosion, damage), and/or bulbs. If an electrical component needs to be tested for proper function, see Section 5.

Hydraulic Brake Systems

CHECKING/BLEEDING

The hydraulic brake systems have been filled and bled at the factory. To check and/or bleed a hydraulic brake system, use the following procedure.

1. With the master cylinder in a level position, check the fluid level in the reservoir. If the level in the reservoir is not visible in the sight glass, add DOT 4 brake fluid.

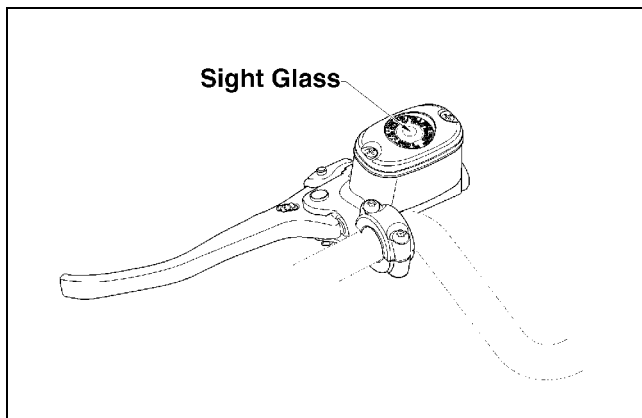

738-420A



CD091

2. Compress the brake lever/pedal several times to check for a firm brake. If the brake is not firm, the system must be bled.

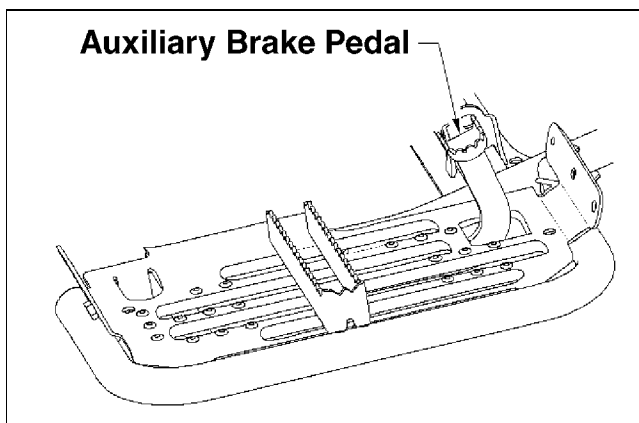

738-437C

3. To bleed the brake system, use the following procedure.
 - A. Remove the cover and fill the reservoir with DOT 4 Hi-Temp Brake Fluid (p/n 1639-799).
 - B. Install and secure the cover; then slowly compress the brake lever several times.
 - C. Remove the protective cap, install one end of a clear hose onto one FRONT bleeder screw, and direct the other end into a container; then while holding slight pressure on the brake lever, open the bleeder screw and watch for air bubbles. Close the bleeder screw before releasing the brake lever. Repeat this procedure until no air bubbles are present.



AF637D

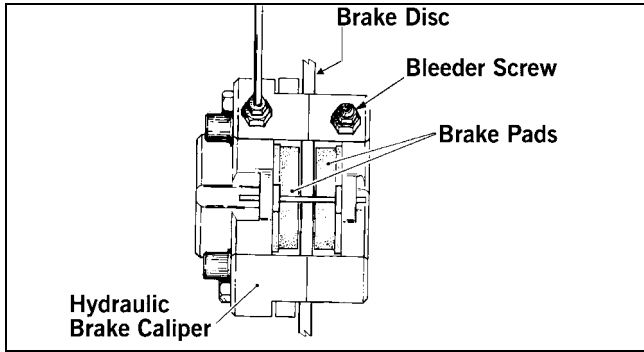

730-434B

■ **NOTE:** During the bleeding procedure, watch the reservoir sight glass very closely to make sure there is always a sufficient amount of brake fluid. When the sight glass changes from dark to light, refill the reservoir before the bleeding procedure is continued. Failure to maintain a sufficient amount of fluid in the reservoir will result in air in the system.

D. Repeat step C until the brake lever is firm.

E. At this point, perform step B, C, and D on the other FRONT bleeder screw; then move to the REAR bleeder screw and follow the same procedure.

4. Carefully check the entire hydraulic brake system that all hose connections are tight, the bleed screws are tight, the protective caps are installed, and no leakage is present.

CAUTION

This hydraulic brake system is designed to use high-temperature DOT 4 brake fluid only. If brake fluid must be added, care must be taken as brake fluid is very corrosive to painted surfaces.

INSPECTING HOSES

Carefully inspect the hydraulic brake hoses for cracks or other damage. If found, the brake hoses must be replaced.

CHECKING/REPLACING PADS

The clearance between the brake pads and brake discs is adjusted automatically as the brake pads wear. The only maintenance that is required is replacement of the brake pads when they show excessive wear. Check the thickness of each of the brake pads as follows.

1. Remove a front wheel.
2. Measure the thickness of each brake pad.

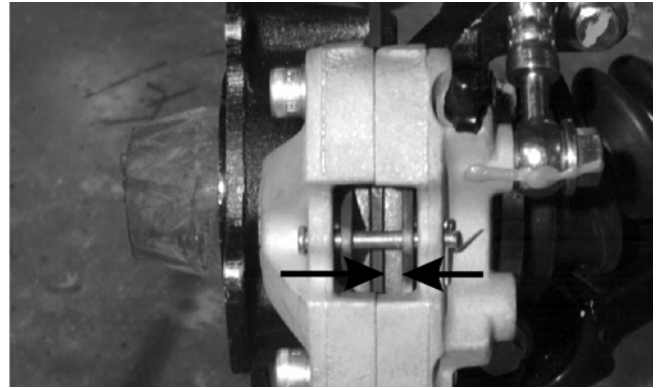

AF739DB

3. If thickness of either brake pad is less than 3.2 mm (0.125 in.), the brake pads must be replaced.

■ **NOTE:** The brake pads should be replaced as a set.

2

4. To replace the brake pads, use the following procedure.

A. Remove the wheel.

B. Remove the cap screws securing the caliper to the bracket; then remove the cotter pin securing the pads and remove the pads.

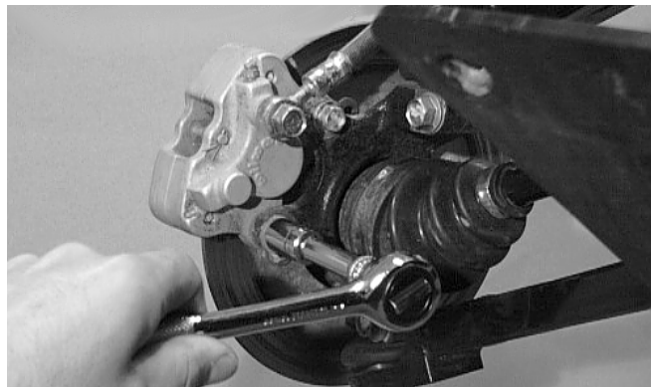

AF615D

C. Install the new brake pads; then secure with the pin and cotter pin. Spread the cotter pin.

D. Secure the caliper to the knuckle and/or axle housing with the cap screws. Tighten to 2.8 kg-m (20 ft-lb).

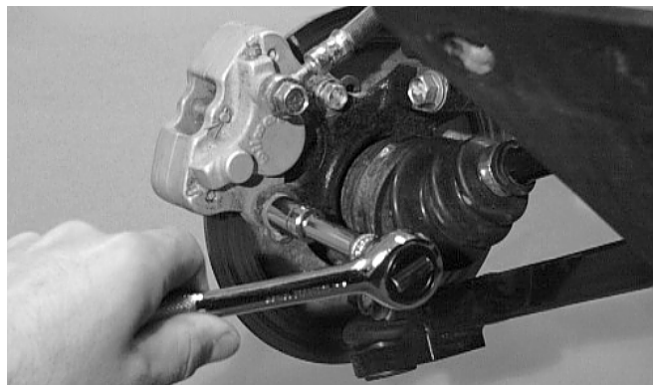

AF615D

- E. Install the wheel. Tighten to 5.5 kg-m (40 ft-lb).
5. Burnish the brake pads (see Burnishing Brake Pads in this section).

Burnishing Brake Pads

All brake pads must be burnished to achieve full braking effectiveness. Braking distance will be extended until brake pads are properly burnished. To properly burnish the brake pads, use the following procedure.

WARNING

Failure to properly burnish the brake pads could lead to premature brake pad wear or brake loss. Brake loss can result in severe injury.

1. Choose an area large enough to safely accelerate the ATV to 30 mph and to brake to a stop.
2. Accelerate to 30 mph; then compress brake lever or apply the auxiliary brake to decelerate to 0-5 mph.
3. Repeat procedure on each brake system five times until brake pads are burnished.
4. Verify that the brakelight illuminates when the hand lever is compressed or the brake pedal is depressed.

Coolant

The cooling system capacity is approximately 2.7 L (2.8 U.S. qt). The cooling system should be inspected daily for leakage and damage. Also, the coolant level should be checked periodically.

When filling the cooling system, use premixed Arctic Cat Antifreeze (p/n 0638-395). While the cooling system is being filled, air pockets may develop; therefore, run the engine for five minutes after the initial fill, shut the engine off, and then fill the cooling system to the upper level mark in the expansion tank.



AN604D

CAUTION

After operating the ATV for the initial 5-10 minutes, stop the engine, allow the engine to cool down, and check the coolant level. Add coolant as necessary.

Checking/Replacing V-Belt

DRAINING COVER

There is a “duck bill” drain for draining water from the V-belt cover.



KX384A

To drain the cover, use the following procedure.

1. Elevate the rear of the ATV (no more than 25°) to allow water trapped in the V-belt cover to run into the cooling inlet duct and drain out through the “duck bill” drain.
2. Shift the range lever to the neutral position; then start the engine.
3. Increase and decrease the RPM several times to “blow out” any water; then stop the engine.

■ **NOTE:** Always inspect the drain whenever servicing/replacing the V-belt.

REMOVING

1. Make sure that the ignition switch is in the off position; then remove the clamps (A) and air duct (B).

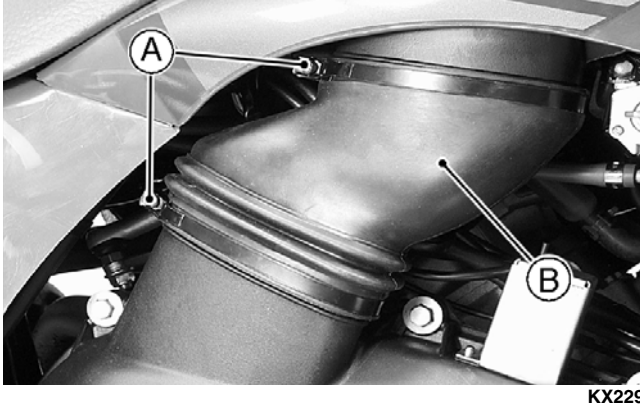

KX229

2. Remove the actuator lead (A) and the Belt Failure Detection Switch lead (B); then remove the cap screws (C) securing the V-belt cover. Remove the cover (D).

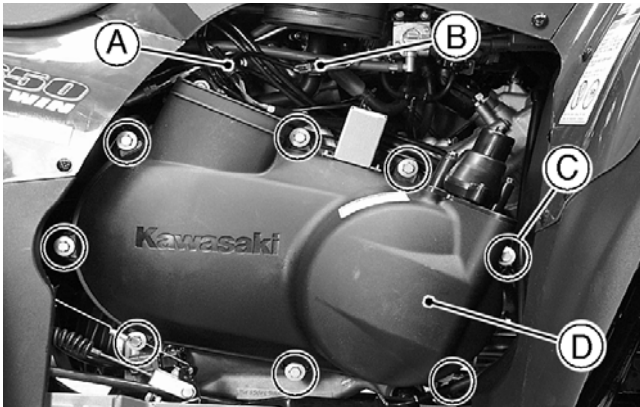

KX230

3. Remove the three cover bolts (B) in the positions shown and install an appropriate drive clutch holder (A) as shown. Note the holder's relative position to the arrow mark (D).

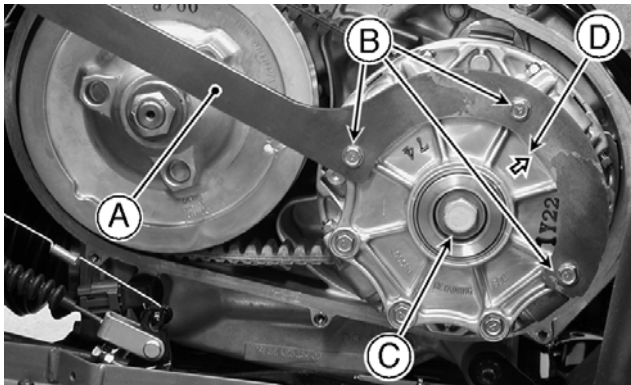

KX231

⚠ CAUTION

Be sure to install the three bolts in the specified positions or the tapped holes will be damaged.

4. Remove the drive clutch cap screw (C) (left-hand threads) and account for two washers and a stepped washer.
5. Remove the drive clutch (C) from the crankshaft using an appropriate clutch puller tool (B) and turning it clockwise while holding the drive clutch with the drive clutch holder (A).

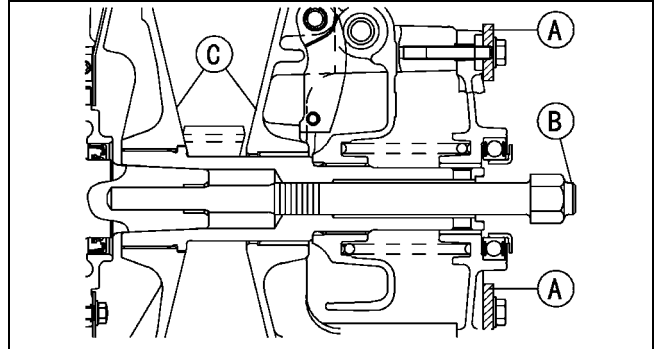

ATV2059

■ **NOTE:** Before removing the belt, note the markings (A) (or mark the belt using tape or marker) in order to reinstall in the same direction as previously installed.

6. Lift the belt (B) off the driven pulley (C).

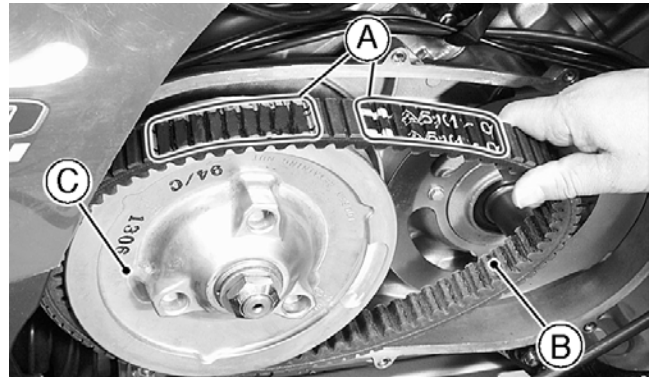

KX232

■ **NOTE:** Inspection of the belt is required every 100 hours or 1100 miles. More frequent inspection is required if the ATV is operated in adverse conditions.

INSPECTING

1. Measure the belt width (A) at several locations using a pair of suitable straightedges (B).

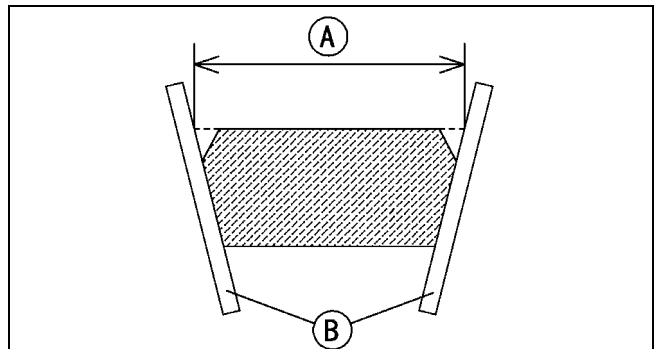

ATV2060

- If belt width is below the service limit of 28.8 mm (1.13 in.) or there is damage to the belt, it must be replaced.

INSTALLING

■ **NOTE:** Be sure to install the belt in the same direction as originally installed. When installing a new belt, direct the top of the lettering (A) toward the engine.

- Loop the belt (B) over the driven pulley (C); then install the drive clutch and tighten to specifications.

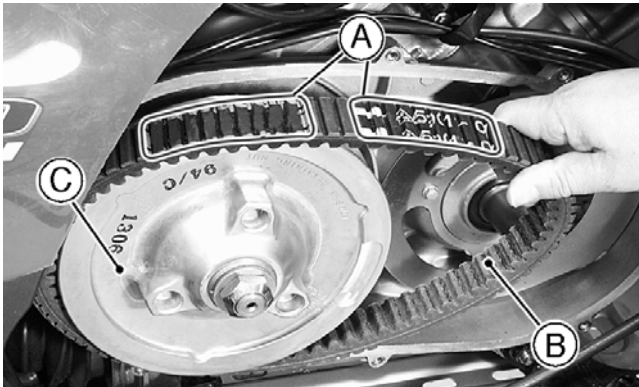

KX232

■ **NOTE:** Make sure the belt is at the top of the driven pulley (A) before checking belt deflection.

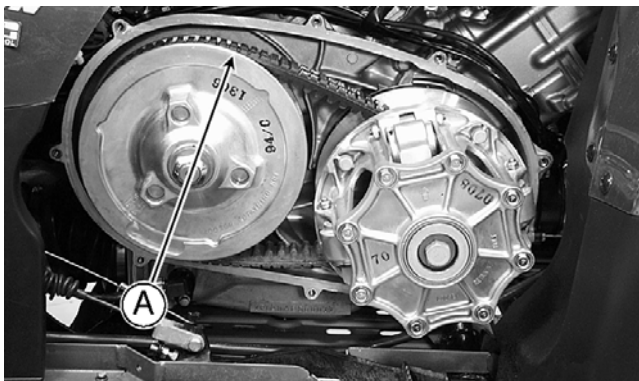

KX233

- Place a straightedge (B) on top of the belt between the drive clutch (C) and the driven pulley (D); then using a ruler, check the belt deflection (A). Use a maximum force of 6 kg (13 lb) on the ruler. Standard belt deflection is 22-27 mm (0.87-1.06 in.). If belt deflection is out of specifications, see Section 3, Right-Side Components.

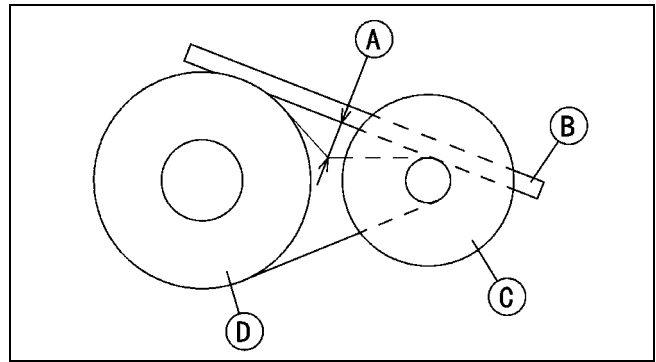

ATV2061

- Check the position of the Belt Failure Detection Switch (A) and reset to the ON position (B).

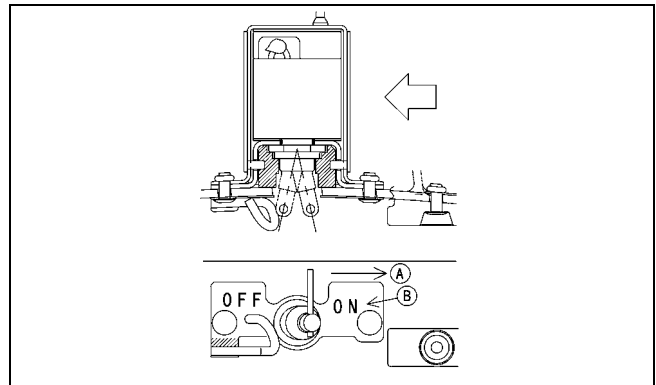

ATV2062A

■ **NOTE:** If the Belt Failure Detection Switch has been tripped to the OFF position, the V-belt cover and switch assembly must be replaced and the V-Belt Failure Mode Clearing procedure (see Section 5) must be performed.

- Install the cover seal into the V-belt cover with the glue joint (A) as shown; then install the V-belt cover and tighten the cap screws to specifications.

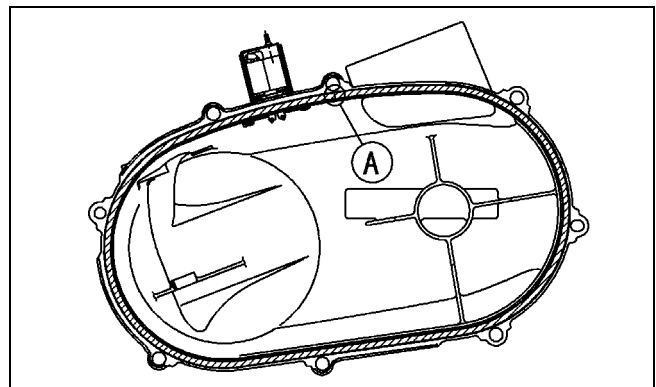

ATV2063

- Connect the actuator lead and the Belt Failure Detection Switch lead; then install the air duct and secure with the clamps.